

# Image Sharpening By Gaussian And Butterworth High Pass Filter

AYUSH DOGRA and PARVINDER BHALLA

Department of ECE, Maharishi Markandeshwar University, Mullana, Ambala, India.

<http://dx.doi.org/10.13005/bpj/545>

(Received: August 10, 2014; accepted: November 05, 2014)

## ABSTRACT

Many significant images contains some extent of noise, that is unexplained variation in data disturbances in image intensity which are either uninterpretable or out of interest. Image analysis is often simplified if this unwanted noise is filtered. For this image simplification, filtering in frequency domain is done. In this paper we will demonstrate the image sharpening by Gaussian & Butterworth high pass filter and jot some points revealing their differences.

**Key words:** Gaussian: Butterworth: image analysis: frequency domain

## INTRODUCTION

Filter out unwanted frequencies from the image is called filtering. The objective of image filtering is to process the image so that the result is more suitable than the original image for a specific applications. Image filtering refers to a process that removes the noise, improves the digital image for varied application. The basic steps in frequency domain filtering are shown in figure 1.

Fourier transform will reflect the frequencies of periodic parts of the image. By applying the inverse Fourier transform the undesired or unwanted frequencies can be removed and this is called masking or filtering. A filter is a matrix, and components of the filters usually vary from 0 to 1. If the component is 1, then the frequency is allowed to pass, if the component is 0 the frequency is tossed out.

A large variety of image processing task can be implemented using various filters. A filter that attenuates high frequencies while passing low frequencies is called low pass filter. Low pass filter are usually used for smoothing. Whereas, a filter that do not affect high frequencies is called high

pass filter. High pass filters are usually used for sharpening. Furthermore, band pass (band reject filter) work on specific frequencies bands. Notch filters work on specific frequencies. Low pass, high pass & band reject filters are often called ideal filters, though they have jumps as shown in figure2.

An ideal filter has the property that all frequencies above (or below) a cut off frequency

$$H(u, v) = \begin{cases} 1 & \text{if } D(u, v) \leq D_0 \\ 0 & \text{otherwise} \end{cases}$$

Where

$$D(u, v) = \left( (u/P - 1/2)^2 + (v/Q - 1/2)^2 \right)^{1/2}.$$

## Gaussian Filter

### Definition

The one-dimensional Gaussian filter has an impulse response given by

$$g(x) = \sqrt{\frac{a}{\pi}} \cdot e^{-a \cdot x^2}$$

And the frequency response is given by

$$\hat{g}(f) = e^{-\frac{\pi^2 f^2}{a}}$$

With  $f$  the ordinary frequency. These equations can also be expressed with the standard deviation as parameter

$$g(x) = \frac{1}{\sqrt{2\pi} \cdot \sigma} \cdot e^{-\frac{x^2}{2\sigma^2}}$$

And the frequency response is given by

$$\hat{g}(f) = e^{-\frac{f^2}{2\sigma_f^2}}$$

By writing  $a$  as a function of  $\sigma$  with the two equations for  $g(x)$  and as a function of  $\sigma_f$  with the two equations for  $\hat{g}(f)$  it can be shown that the product of the standard deviation and the standard deviation in the frequency domain is given by

$$\sigma \cdot \sigma_f = \frac{1}{2\pi}$$

Where the standard deviations are expressed in their physical units, e.g. in the case of time and frequency in seconds and Hertz.

In two dimensions, it is the product of two

$$g(x, y) = \frac{1}{2\pi\sigma^2} \cdot e^{-\frac{x^2+y^2}{2\sigma^2}} \quad [3, 4, 5]$$

Where  $x$  is the distance from the origin in the horizontal axis,  $y$  is the distance from the origin in the vertical axis, and  $\sigma$  is the standard deviation of the Gaussian distribution.

**Gaussian Low Pass And High Pass Filter In Frequency Domain [1, 2, 7]**

In the case of Gaussian filtering, the frequency coefficients are not cut abruptly, but

smoother cut off process is used instead. Thus also takes advantage of the fact that the DFT of a Gaussian function is also a Gaussian function shown in figure 6,7,8,9. The Gaussian low pass filter attenuates frequency components that are further away from the centre ( $W/2, H/2$ ),  $A \sim 1/\delta$  Where  $\delta$  is standard deviation of the equivalent spatial domain Gaussian filter.

$$X'_{uv} = X_{uv} e^{-\frac{\left(\frac{H}{2}-u\right)^2 + \left(\frac{W}{2}-v\right)^2}{A^2}}$$

The Gaussian high pass filter attenuates frequency components that are near to the image

$$X'_{uv} = X_{uv} \left( 1 - e^{-\frac{\left(\frac{H}{2}-u\right)^2 + \left(\frac{W}{2}-v\right)^2}{A^2}} \right)$$

Figure 3, 4, 5 shows the result of Gaussian filter. Ringing (wave) effect is avoided in the Gaussian filter.

**Butterworth filter**

**Definition**

Another version of smoothing/ sharpening filters are the Butterworth filter. A Butterworth filter of order  $n$  and cutoff frequency  $D_0$  is defined as [2, 7]

$$H(u, v) = \frac{1}{1 + [D(u, v)/D_0]^{2n}}$$

An advantage with the Butterworth filter is that we can control the sharpness of the filter with the order.

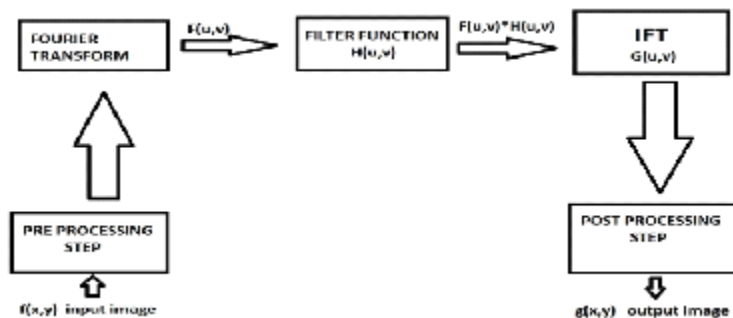
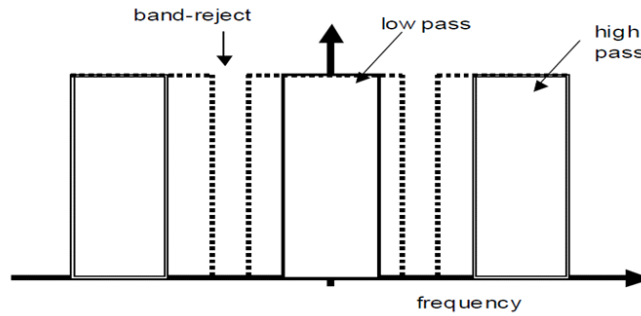

Fig. 1: basic steps for filtering in frequency domain

**Butterworth low pass filter**

A Butterworth low pass filter keeps frequencies inside radius  $D_0$  and discards value outside it. It introduces a gradual transition from 1 to 0 to reduce ringing artifacts. The transfer function of a Butterworth low pass filter (BLPF) of order  $n$ , and with cutoff frequency at distance  $D_0$  from the origin, is defined as [2, 7]

Figure 11, 12, 13, 14, 15 show the result of applying Butterworth low pass filter to figure 10, with  $n = 2$  and  $D_0$  equal to 10, 30, 60, 160 and 460. Therefore notice a smooth transition in blurring as a function of increasing cutoff frequency. No ringing is visible in any of the images processed with this particular BLPF.



**Fig. 2: ideal filters**



**Fig. 3: original image**



**Fig. 4: Result of Gaussian low pass filter**



**Fig. 5: Gaussian high pass filter**

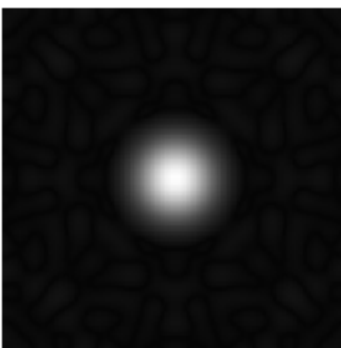

**Fig. 6: Low pass filter in the frequency domain**

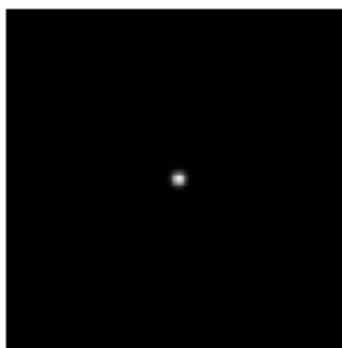

**Fig. 7: Low pass filter in the spatial domain**



**Fig. 8: High pass filter in the frequency domain**

**Butterworth High Pass Filter [1, 2, 7]**

A Butterworth high pass filter keeps frequencies outside radius  $D_0$  and discards values inside. It has a gradual transition from 0 to 1 to reduce ringing artifacts. A Butterworth high pass filter (BHPF) of order  $n$  and cutoff frequency  $D_0$  is defined as

$$H(u, v) = \frac{1}{1 + [D_0/D(u, v)]^{2n}}$$

Figure 17, 18,19 shows the result of applying Butterworth high pass filter on figure 16, with  $n = 2$ , and  $D_0$  equal to 30,60 and 160. These results are much smoother. The boundaries are much less distorted, even for the smallest value of cutoff frequency. The transition into higher values of cutoff frequencies is much smoother with the BHPF.

**3D Perspective Plot Of Filter's Transfer Function [2]**

The ideal low pass filter is radially symmetric about the origin, which means that the filter is completely defined by radial cross section as shown in figure 20. Unlike the ILPF, the BLPF transfer function does not have a sharp discontinuity that gives a clear cutoff between passed and filtered

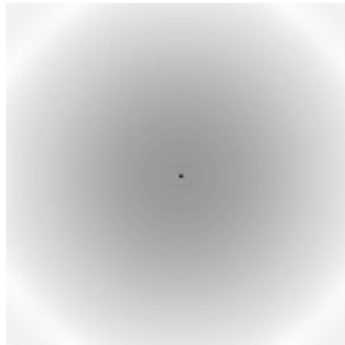

**Fig. 9: High pass filter in the Spatial domain**



**Fig. 10: original image**



**Fig. 11: result of filtering with Cutoff frequency set at radius value 10**



**Fig. 12: result of filtering with Cutoff frequency set at radius value 30**



**Fig. 13: result of filtering with Cutoff frequency set at radius value 60**



**Fig. 14: result of filtering with Cutoff frequency set at radius value 160**



**Fig. 15: result of filtering with Cutoff frequency set at radius value 460**



Fig. 16: Original image



Fig. 17: result of BHPF of order 2 with  $D_0 = 30$



Fig. 18: result of BHPF of order 2 with  $D_0 = 60$



Fig. 19: result of BHPF of order 2 with  $D_0 = 160$

Frequencies as depicted in figure 21. For filter with smooth transfer functions, defining a cutoff frequency locus at points for which  $H(u, v)$  is down to a certain fraction of its maximum value is customary. Perspective 3D plot of GLPF is shown in figure 22. Unlike the ILPF, GLPF transfer function also does not have sharp discontinuity but it is much smoother than BLPF. Butterworth filter represents the transition between the sharpness of the ideal filter and broad smoothness of the Gaussian filter. Figure 23, 24, and 25 shows the perspective 3D plots of IHPF, BHPF and GHPF.

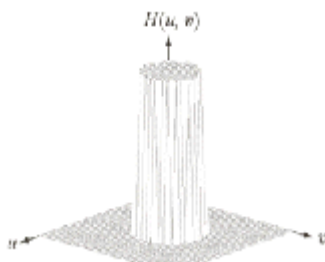

Fig. 20: perspective plot of an ILPF transfer function

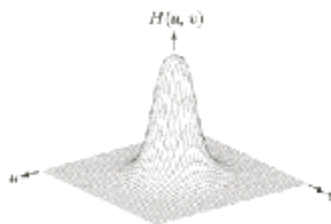

Fig. 21: Perspective plot of BLPF transfer function

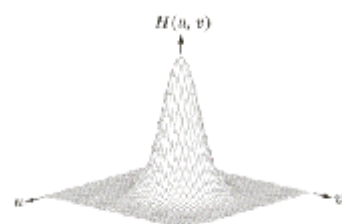

Fig. 22: perspective plot of GLPF transfer function

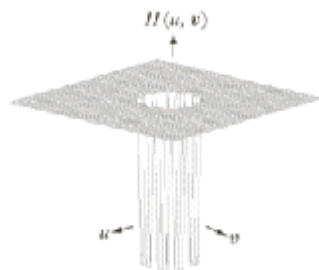

Fig. 23: Perspective plot of an IHPF transfer function

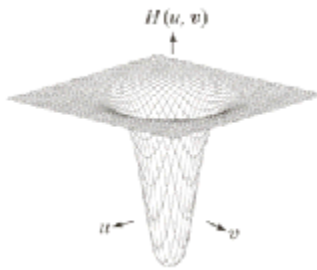

Fig. 24: Perspective plot of BHPF transfer function

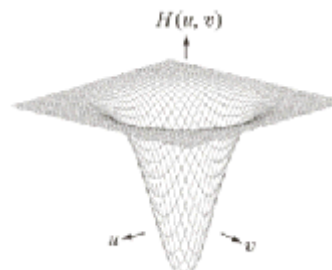

Fig. 25: Perspective plot of GHPF transfer function

### Image Sharpening With Gaussian & Butterworth High Pass Filter

High pass filter give emphasis to the higher frequencies in the image. The high pass image is then added to the original image so as to obtain a sharper image. [6] It may be interesting to experiment with width and frequency threshold of the Butterworth or the Gaussian high pass filters and it will really interesting to compare the

sharpening which is done in frequency domain and can compare it with the sharpening done in spatial domain. We will only demonstrate the image sharpening using Gaussian and Butterworth high pass filter taking  $D_0=100, n=4$  (where  $D_0$  is cutoff frequency,  $n$  is the order of the filter) . Figure 26 is the CT image, figure 27 depicts the FFT of the image, and figure 28 shows the Butterworth high pass filter of FFT image. Figure 29 shows the

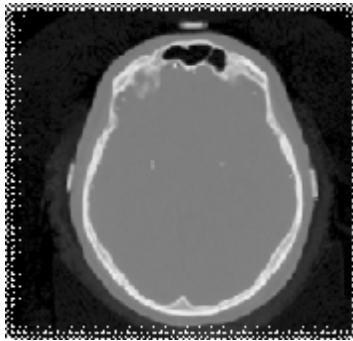

Fig. 26: CT image

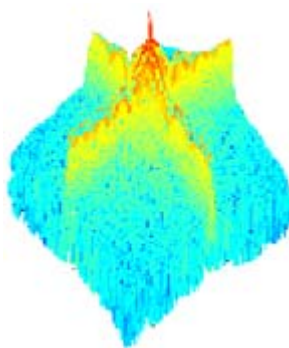

Fig. 27: FFT of CT image

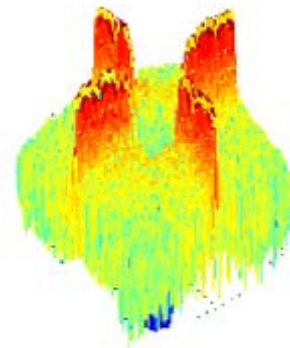

Fig. 28: BHPF of FFT image

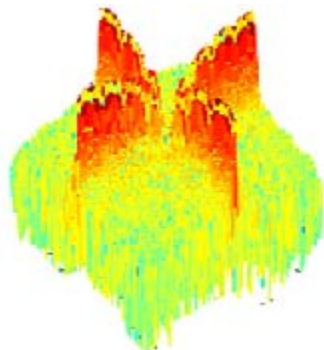

Fig. 29: GHPF of FFT image

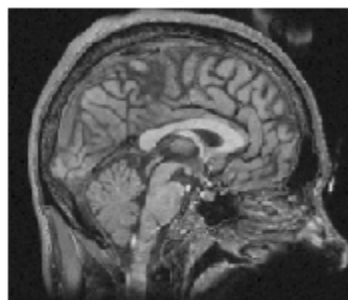

Fig. 30: MRI image

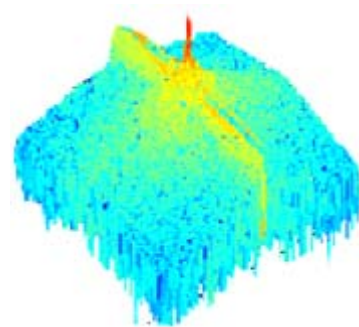

Fig. 31: FFT of MRI image

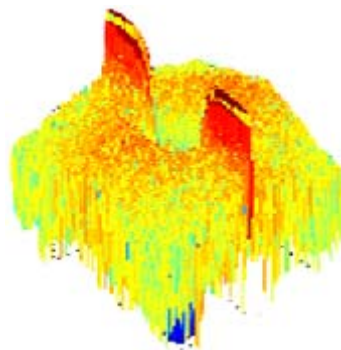

Fig. 32: BHPF of FFT MRI image



Fig. 33: GHPF of FFT MRI image

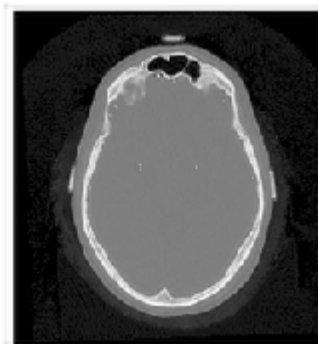
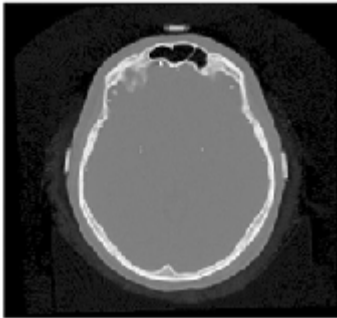
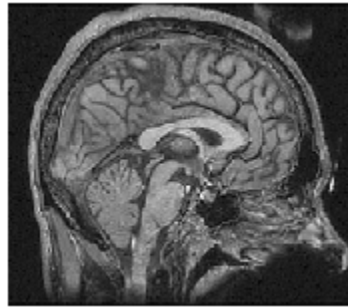

Fig. 34: Sharpened image by BHPF



**Fig. 35: Sharpened image by GHPF**



**Fig. 36: Sharpened image by BHPF**

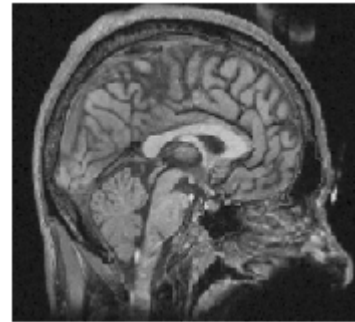

**Fig. 37: Sharpened image by GHPF**

Gaussian high pass filter of FFT image. Similar examples are shown with MRI image in figure 30. Figure 31, 32, 33 shows FFT of image, Butterworth high pass filter of FFT image, Gaussian high pass filter of FFT image. Now the resultant sharpened images of CT and MRI image are shown in figure 34,35,36,37. Now these sharpened images can be used in various image processing tasks, like edge detection and ridge detection.

### RESULTS

We use  $D_0=100, n=4$  & uses Gaussian and Butterworth high pass filter . High pass filter give

emphasis on the high frequencies in the image. The difference between Butterworth and Gaussian filters is that the former is much sharper than latter. The resultant images by BHPF is much sharper than GHPF ,while analysis the FFT of CT and MRI image, one sharp spike is concentrated in the middle. By applying BHPF & GHPF on the images, we find drastically change in the color intensities of high pass filter of FFT images. The split edges are elongated and wider in BHPF case than GHPF. But in GHPF case the split edges are sharper. These elongated split edges in BHPF leads to sharper image than GHPF.

### REFERENCES

1. Umbaugh Scot E, *Computer Vision and Image Processing*, Prentice Hall, NJ, 1988, ISBN 0-13-264599-8
2. R.C.Gonzales, R.E.Woods, *Digital Image Processing*, 2-nd Edition, Prentice Hall, 2002
3. R.A. Haddad and A.N. Akansu, "A Class of Fast Gaussian Binomial Filters for Speech and Image Processing," *IEEE Transactions on Acoustics, Speech and Signal Processing*, vol. 39, pp 723-727, March 1991.
4. Shapiro, L. G. & Stockman, G. C: "Computer Vision", page 137, 150. Prentence Hall, 2001
5. Mark S. Nixon and Alberto S. Aguado. *Feature Extraction and Image Processing*. Academic Press, 2008, p. 88.
6. Yusuf, Nijad, Sara Tedmory "Exploiting hybrid methods for enhancing digital X-ray images". *The International Arab Journal of Information Technology*, Vol. 10, No.1, January 2013
7. Gonzales R., Woods R., and Eddins S., *Digital Image Processing Using Matlab*, 2nd Edition, Prentice Hall, USA, 2003.